

Monako

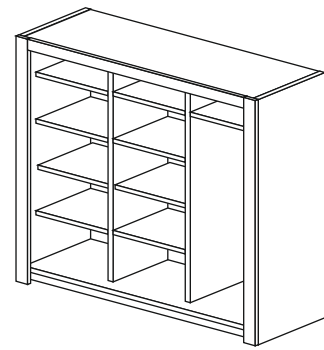

- (PL)** Instrukcja montażu
- (D)** Aufbauanleitung
- (GB)** Assembly instruction
- (SK)** Návod na montáž

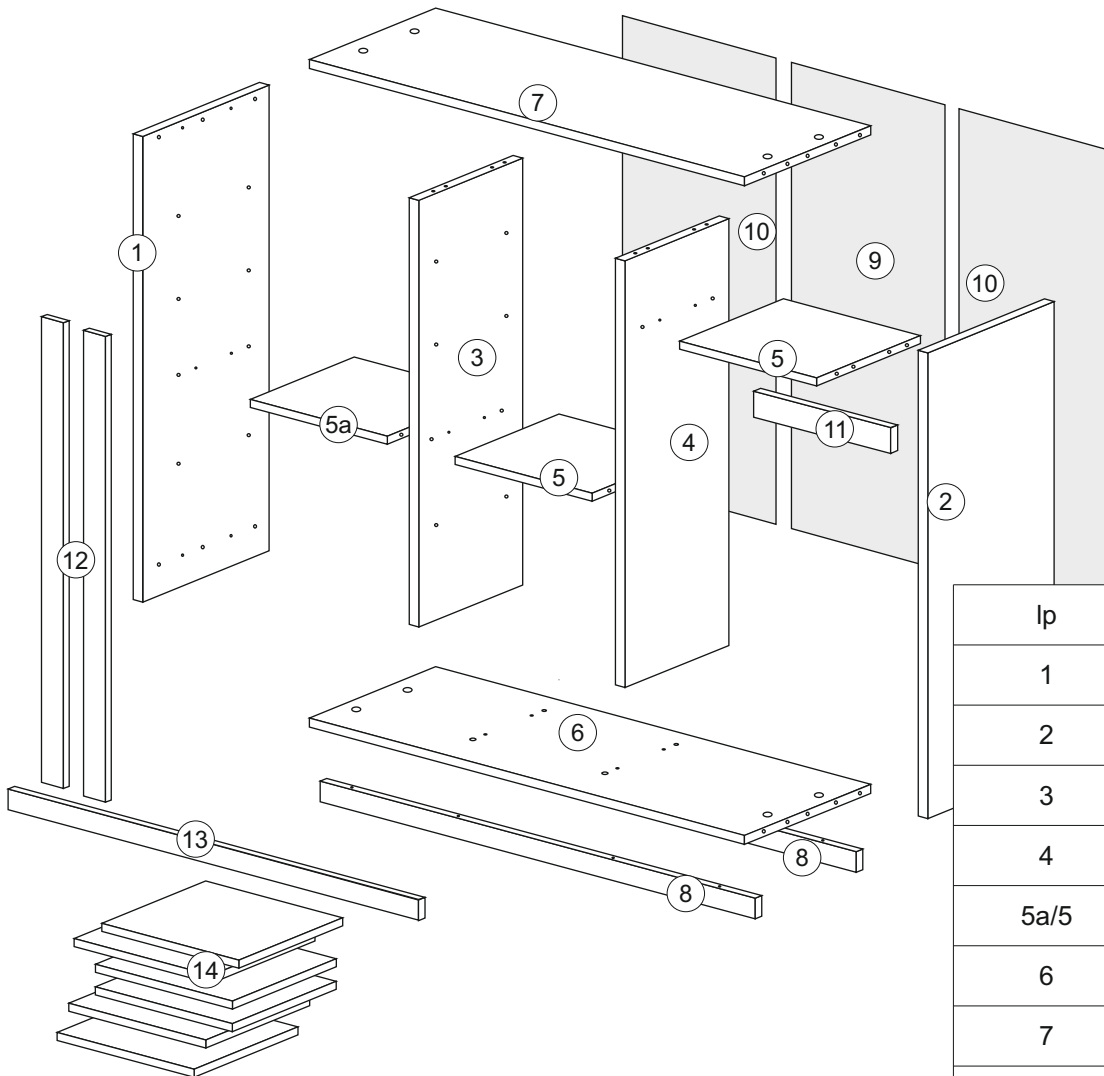

- Karta gwarancyjna**
- der Garantieschein**
- Guarantee certificate**
- Záručný list**

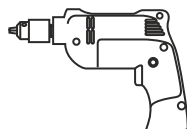
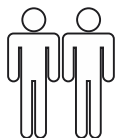
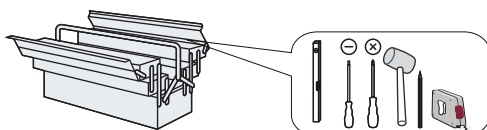

lp	wymiar	ilość
1	1990x619	1
2	1990x619	1
3	1877x500	1
4	1877x500	1
5a/5	662x500	1/2
6	2018x619	1
7	2018x619	1
8	2018x80	2
9	1906x678	1
10	1906x684	2
11	662x123	1
12	1990x80	2
13	1893x80	1
14	662x500	6
15	1857x690	3

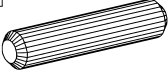
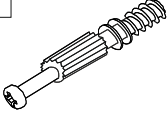

Akcesoria - Accessories - die Accessoires

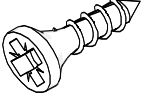
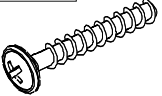
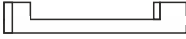
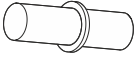
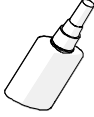
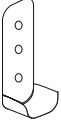
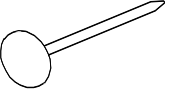
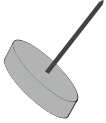
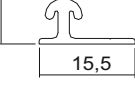
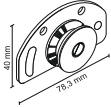
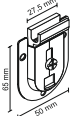
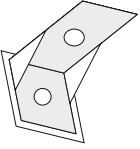
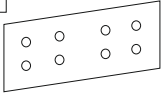
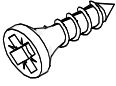
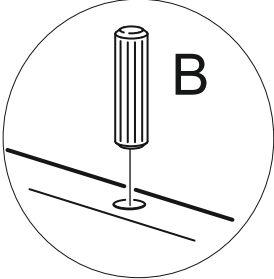
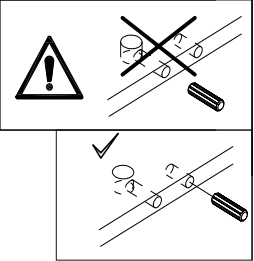
S	 x12	B	 x38	C	 x28	D	 x28	F 3.5x16	 x90
G 4x25	 x4	H	 x2	I	 x24	J	 x1	K	 x2
M.	 x100	P.	 x8	U	 x4	U1	 x6	U2	 x6
V	 x22	W	 x2	Y 3x16	 x16				

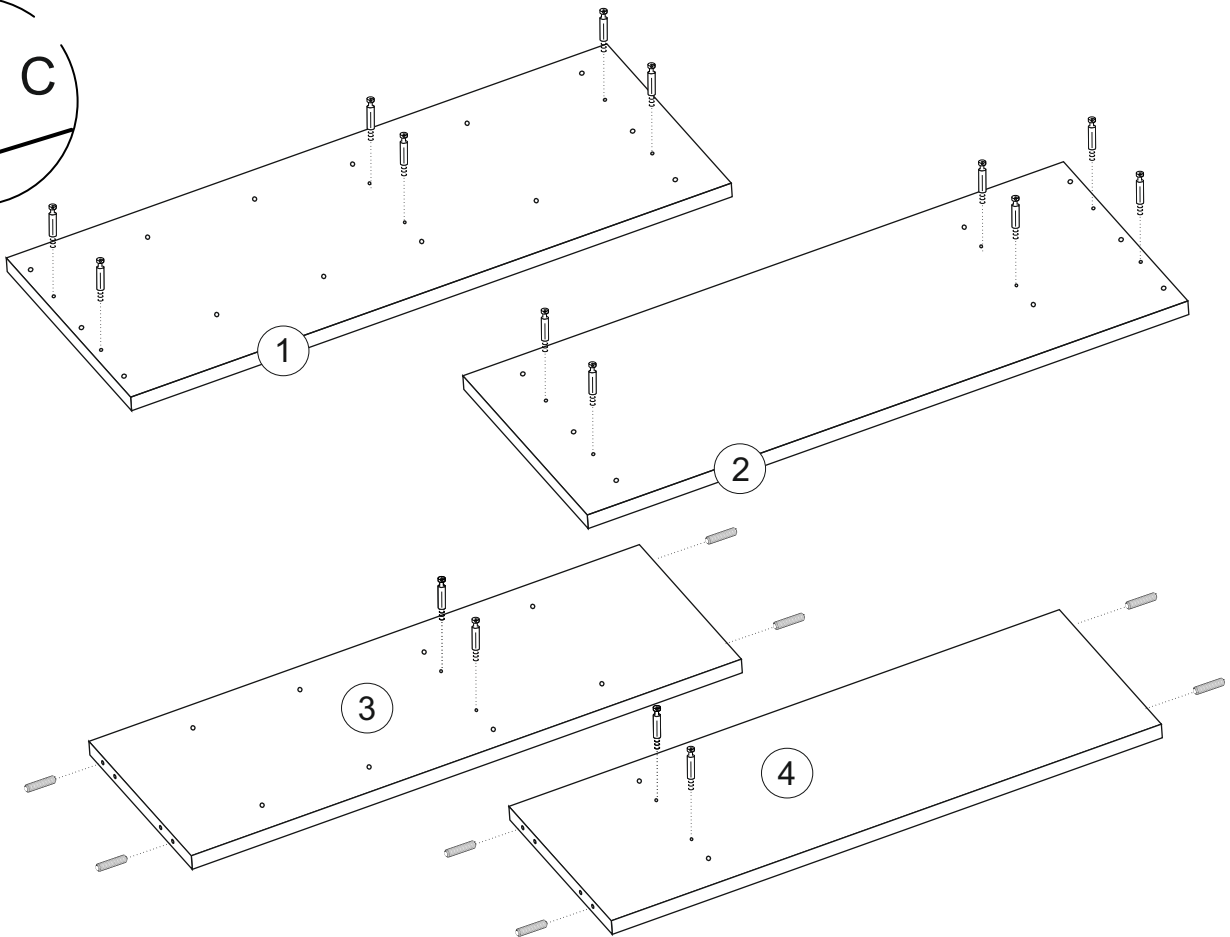
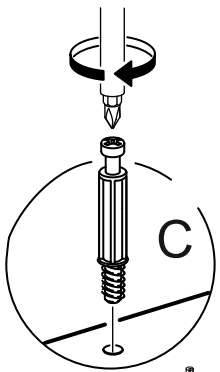

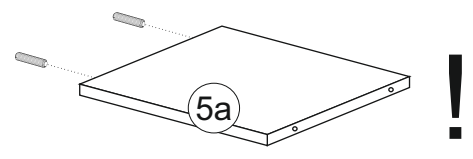
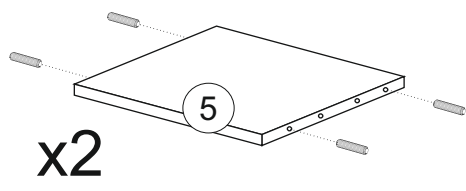
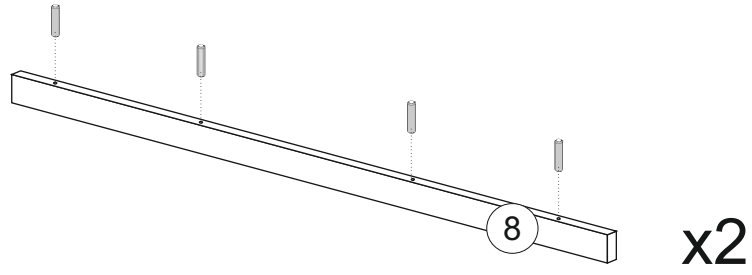
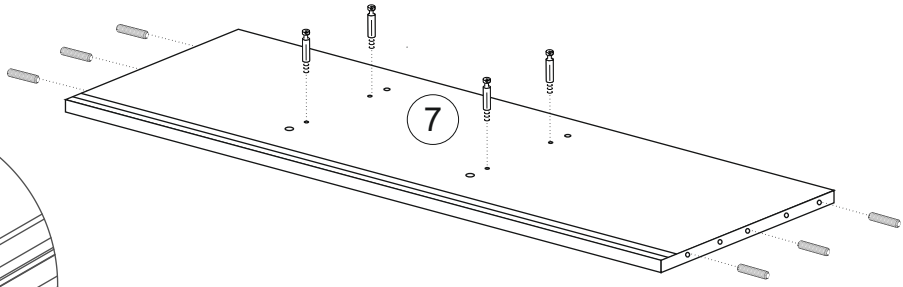
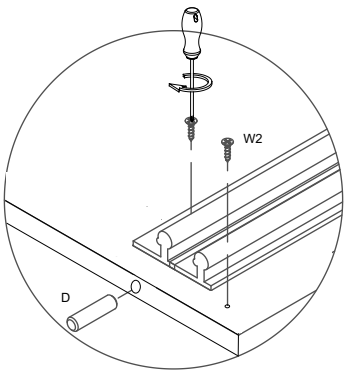
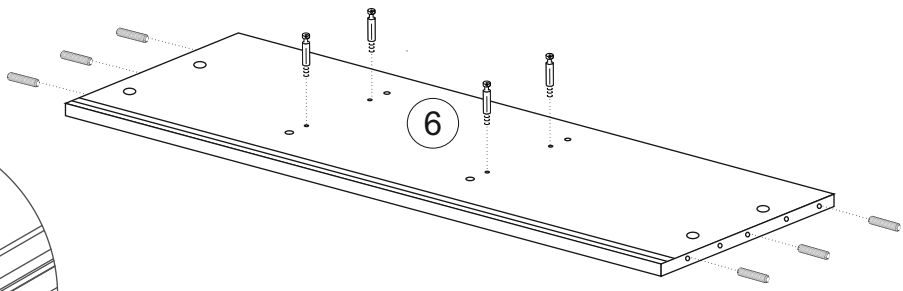
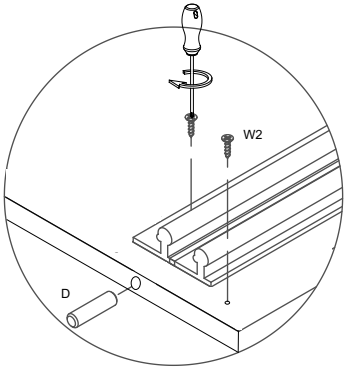

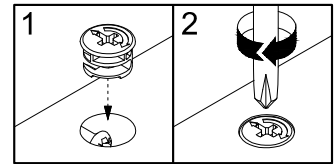
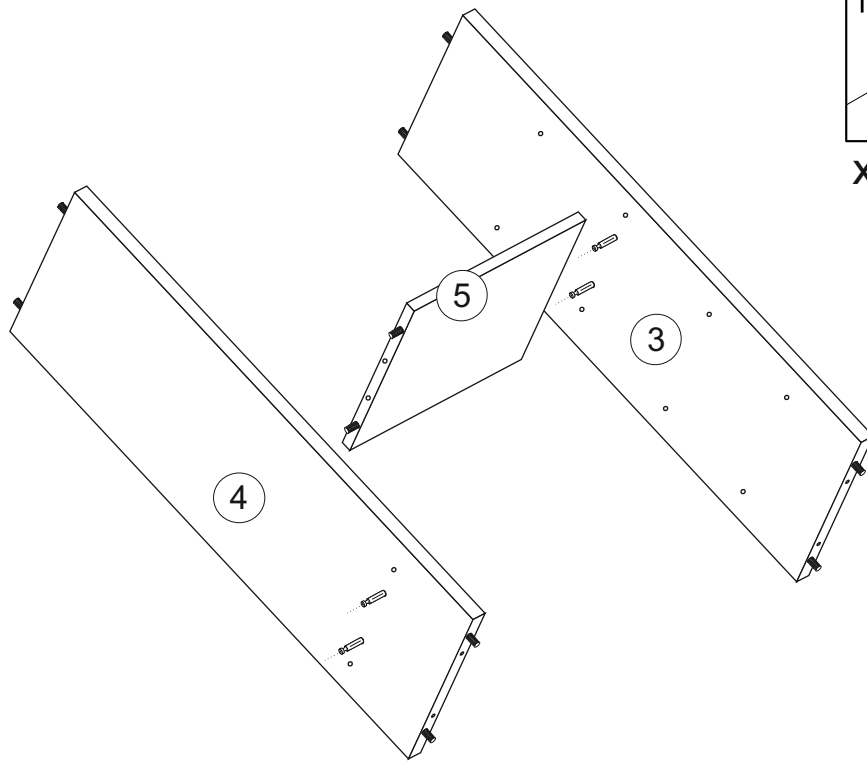

x4

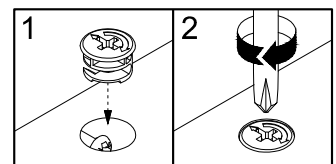
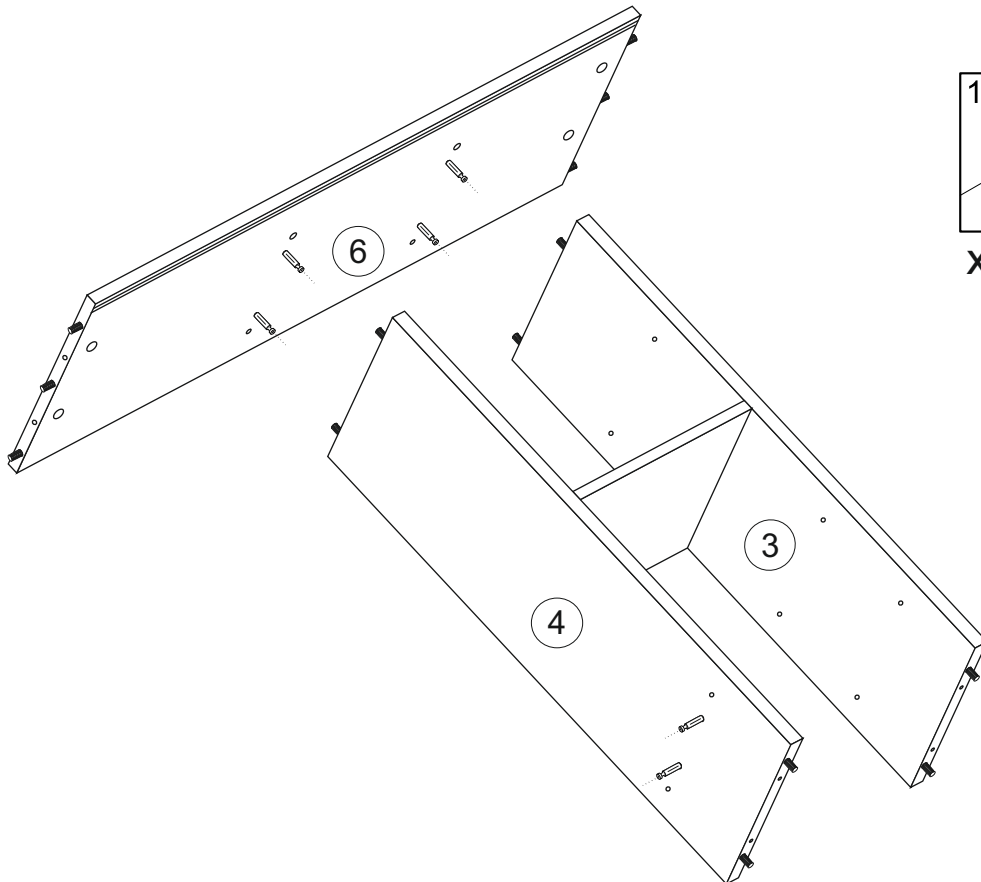

x4

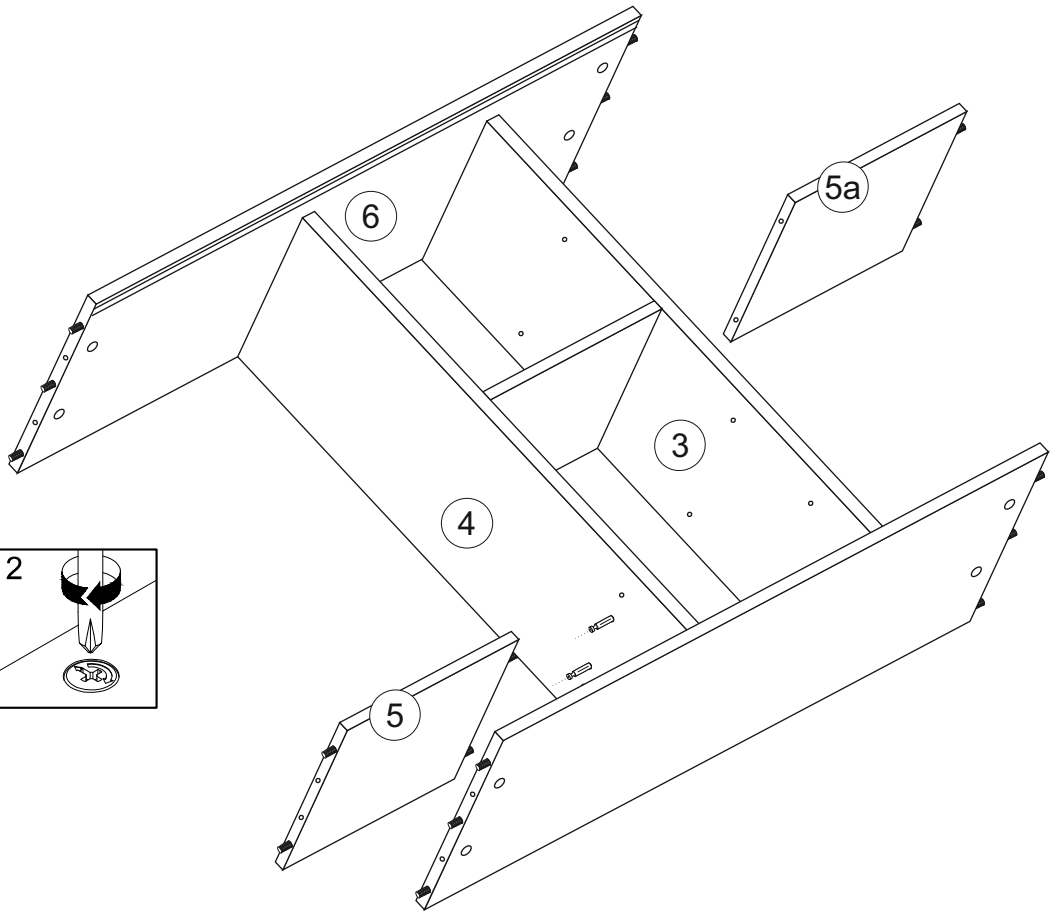
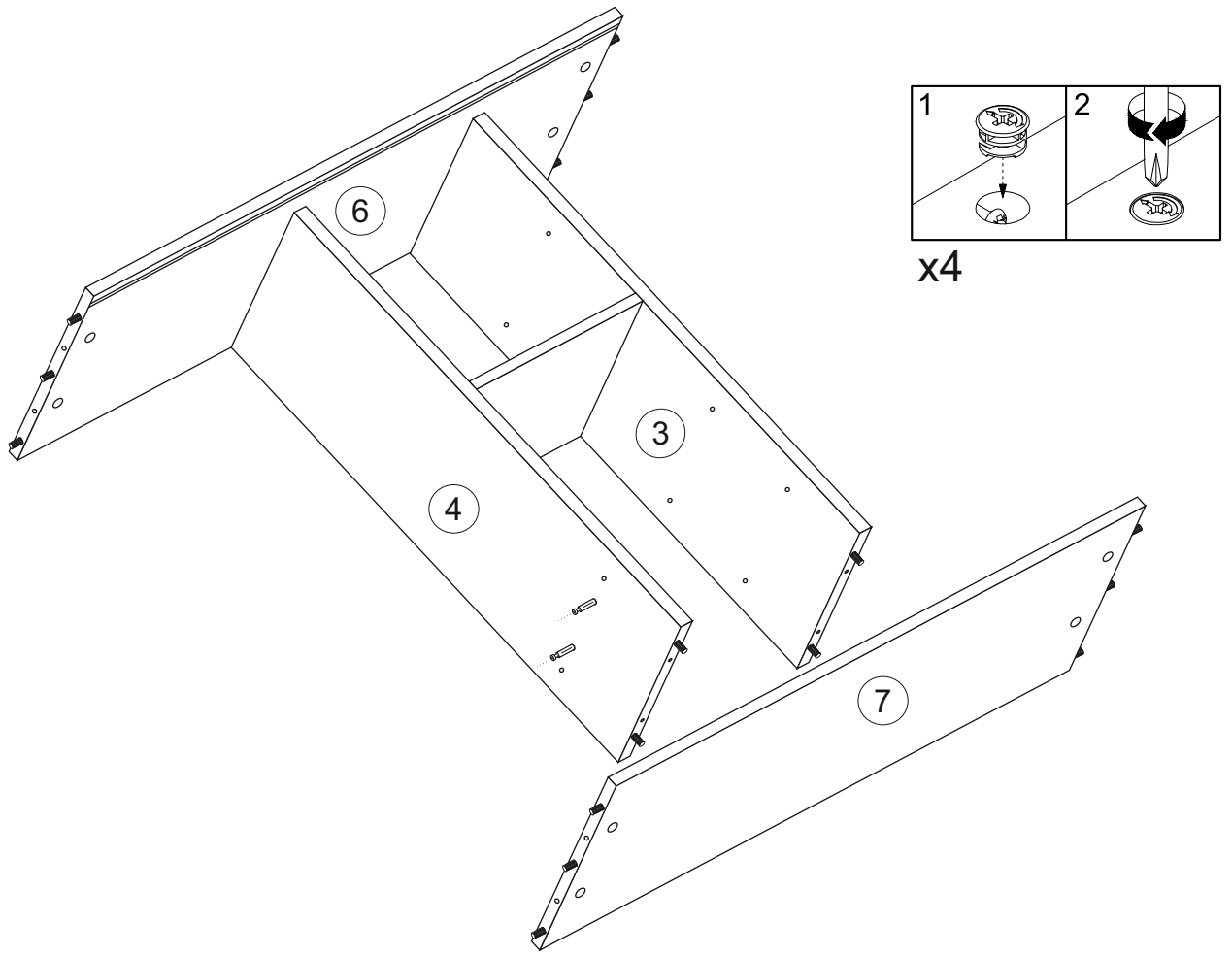

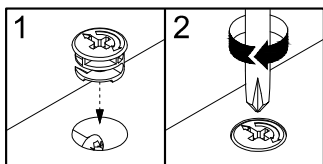

x6

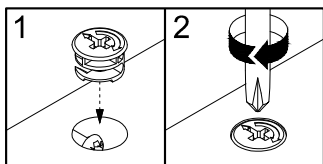
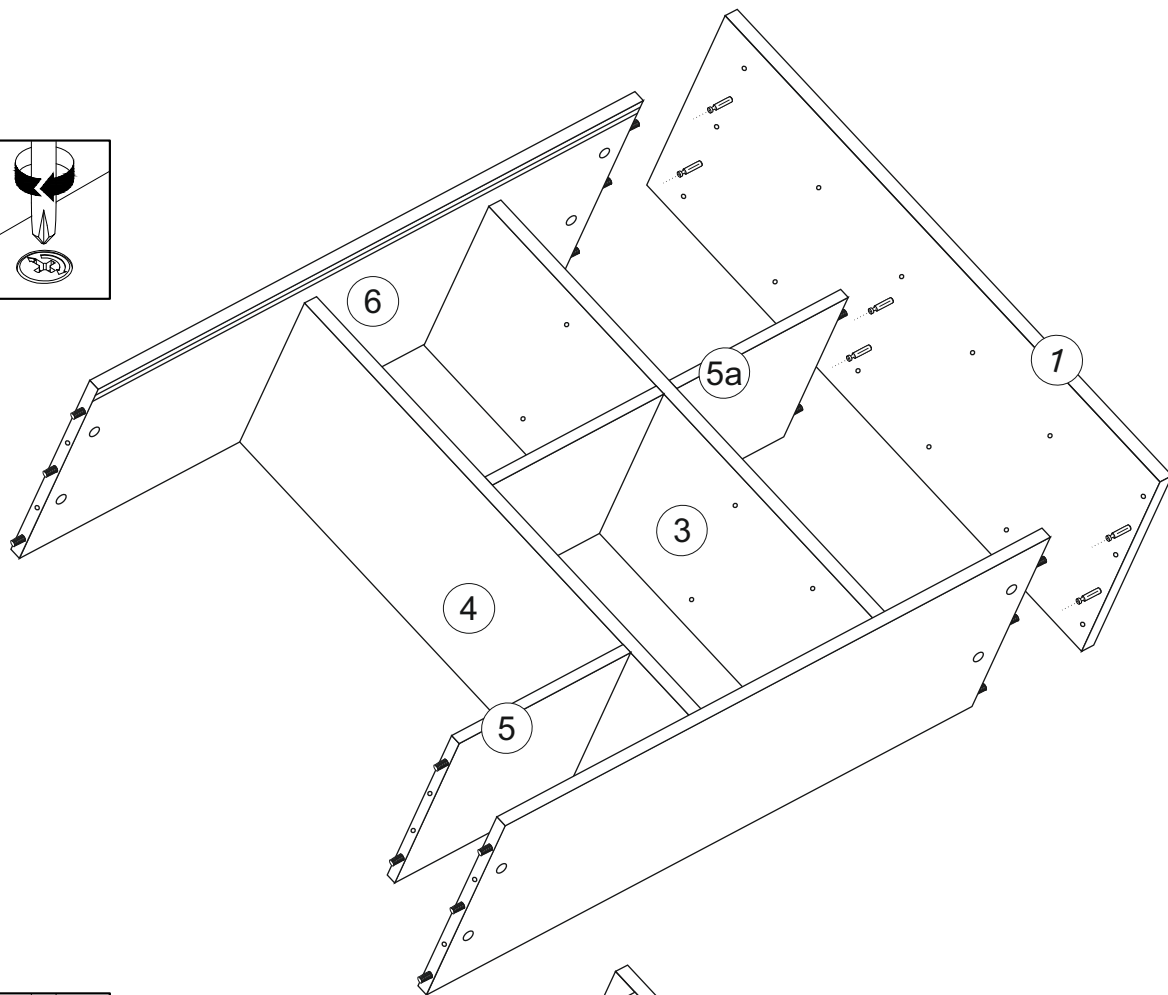

x6

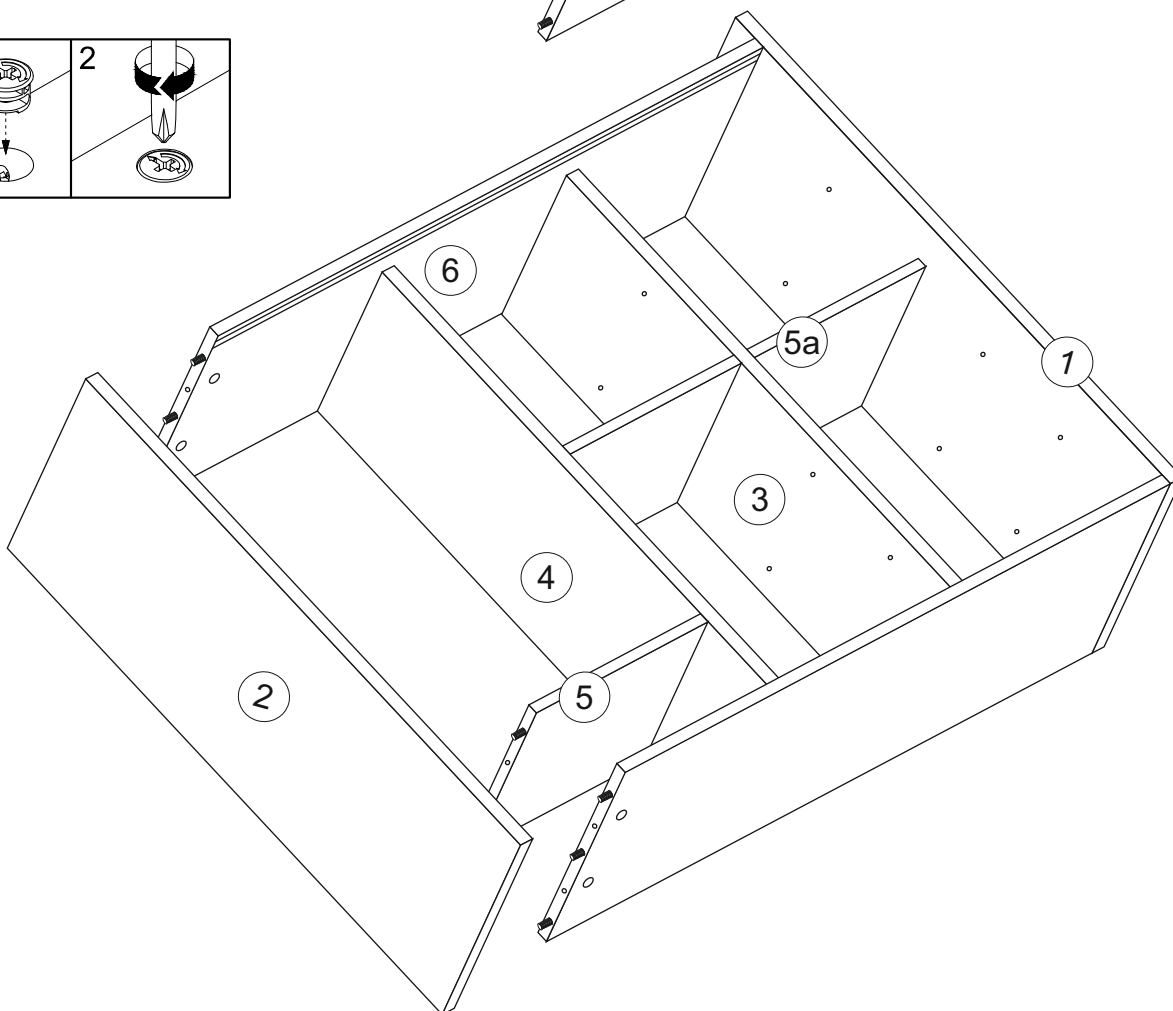

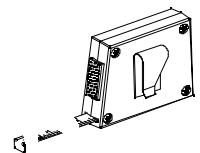
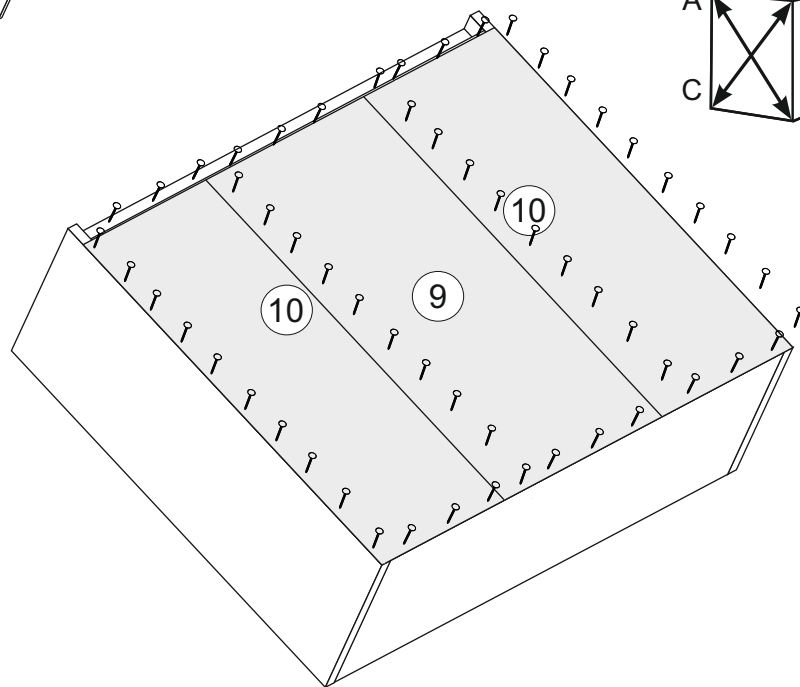
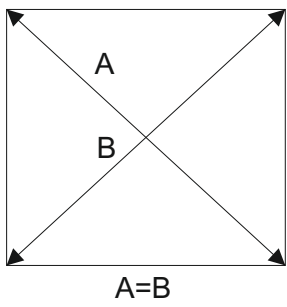
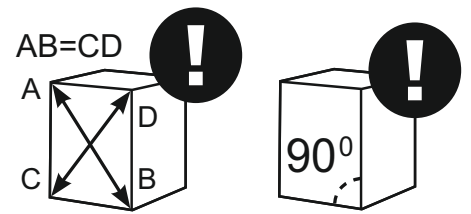
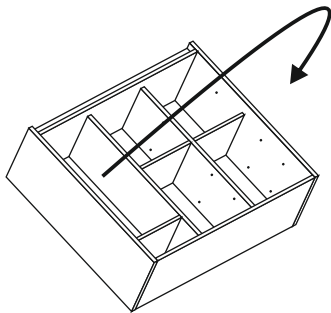
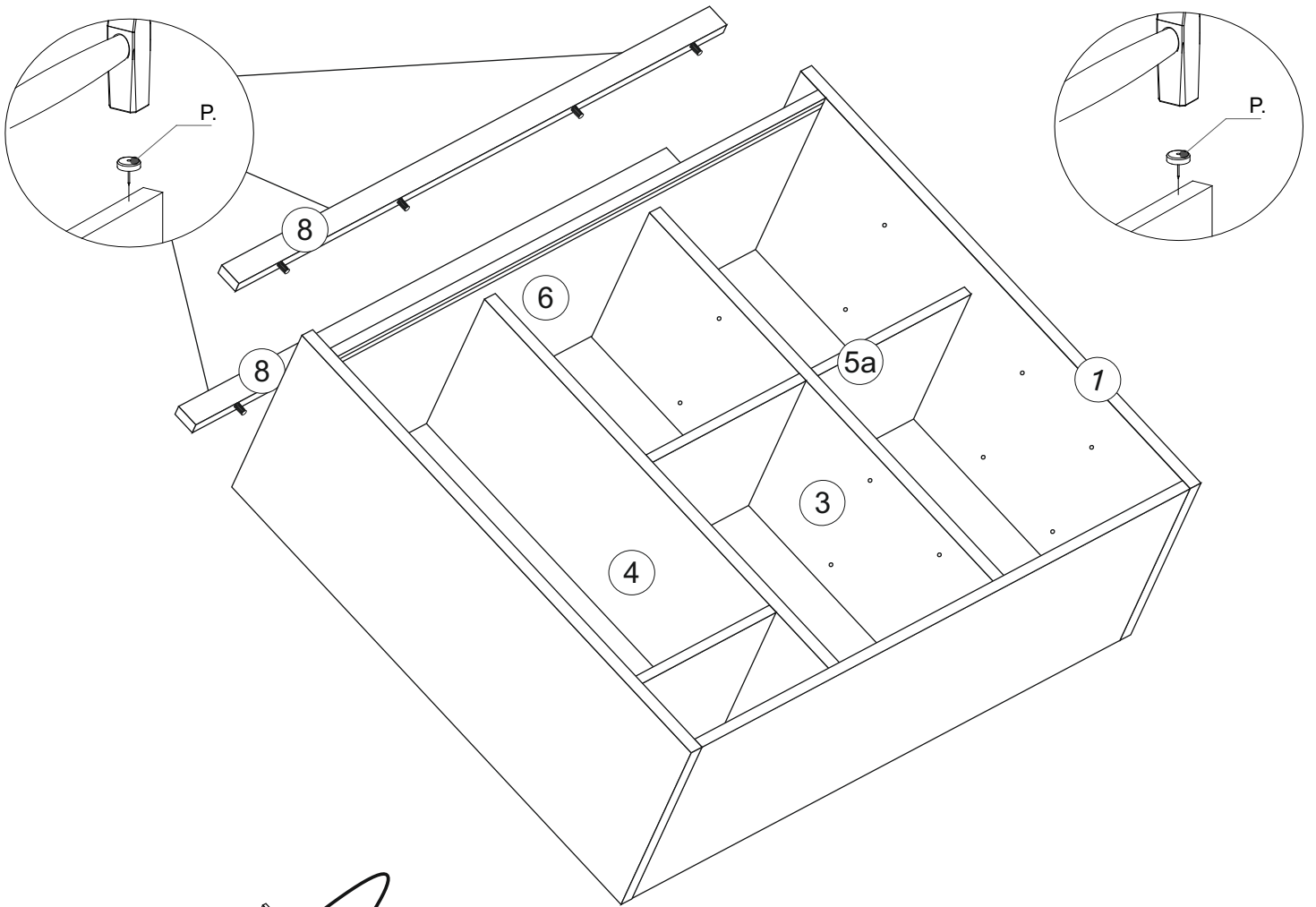

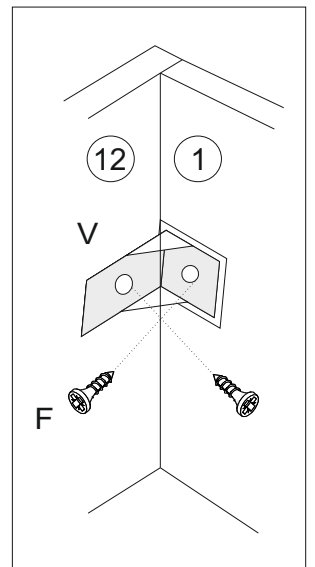
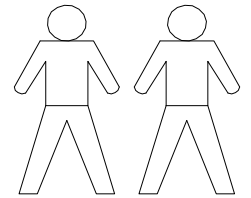
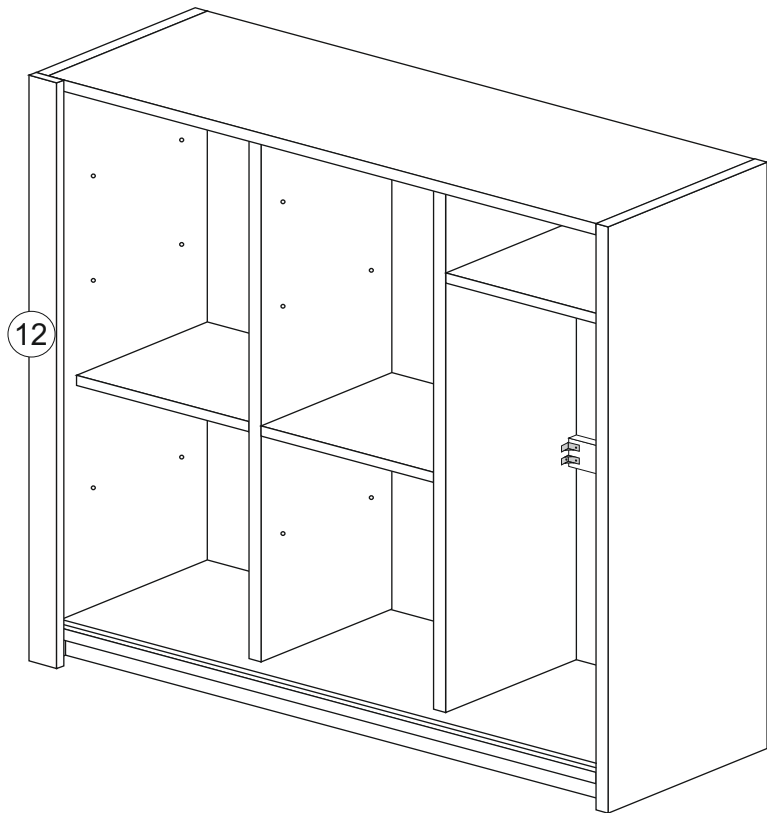
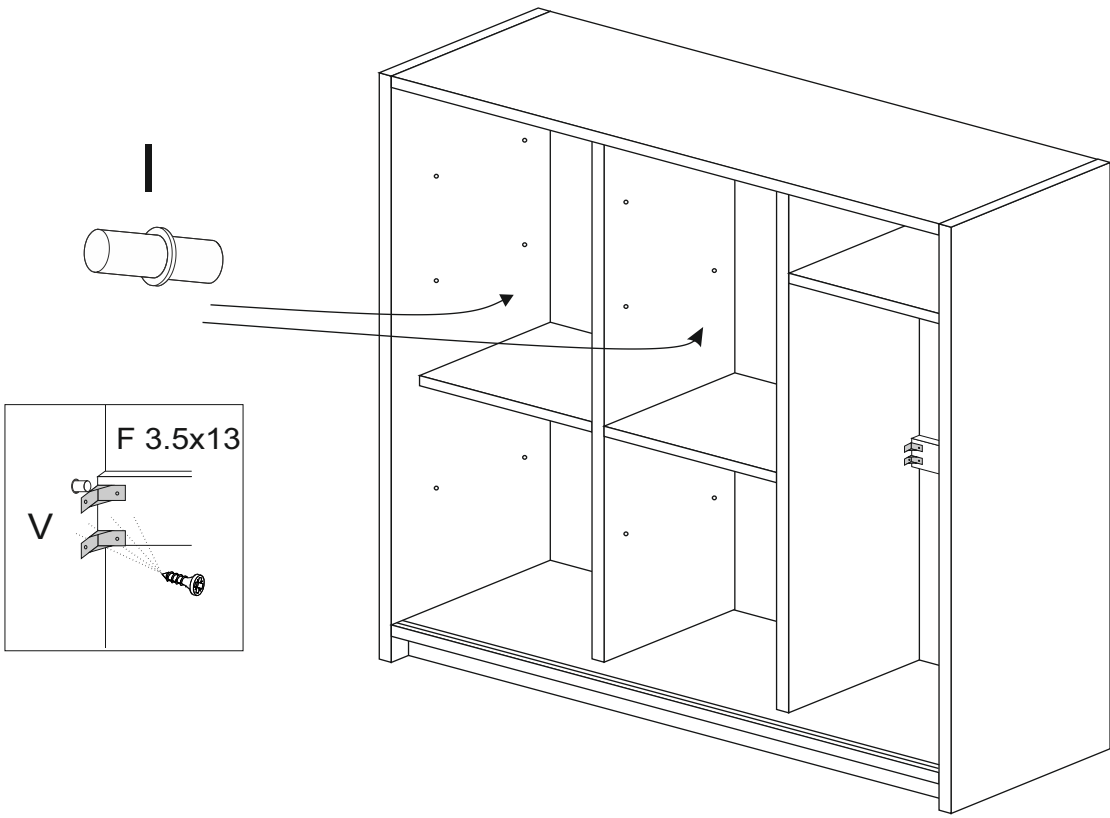

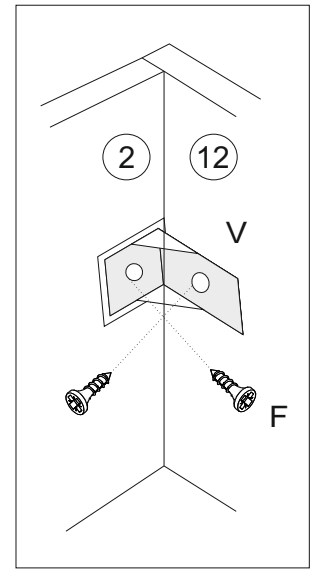
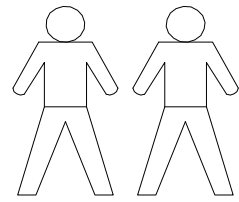
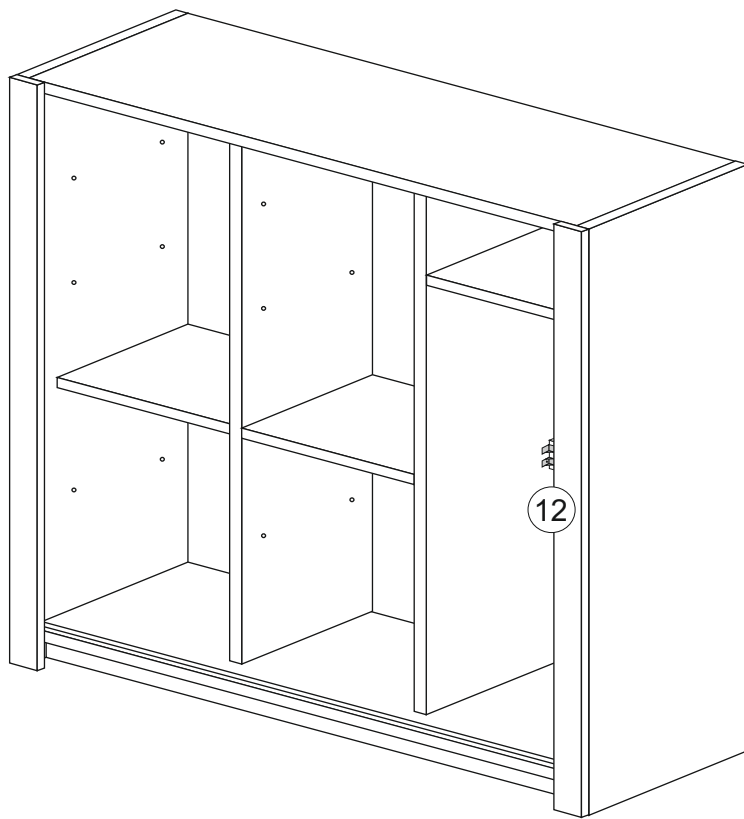

1.

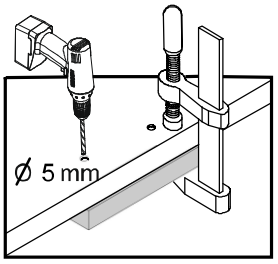

2.

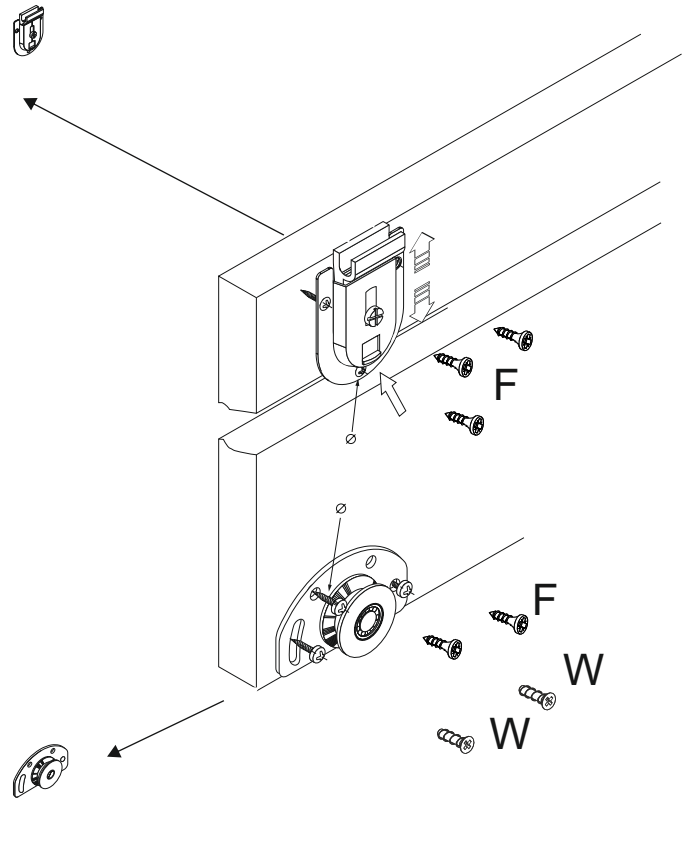
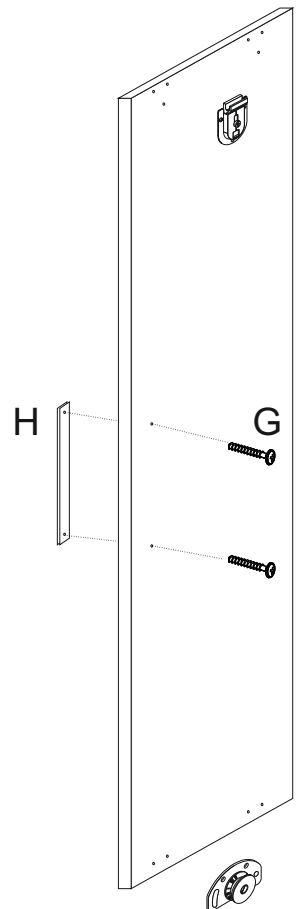
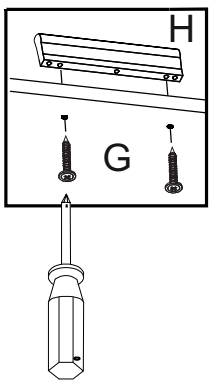

9

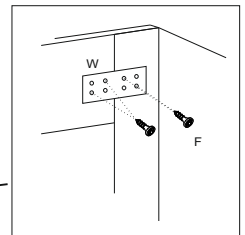
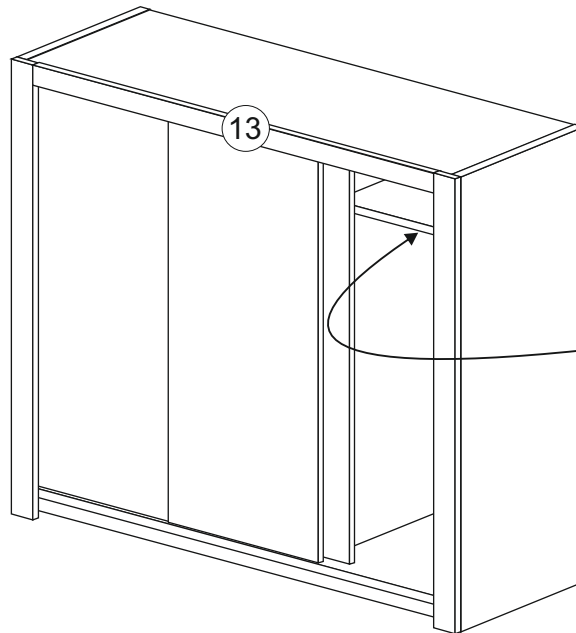
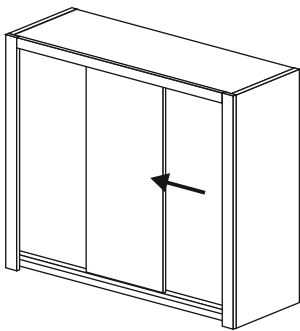
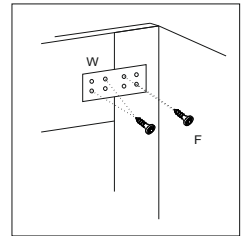
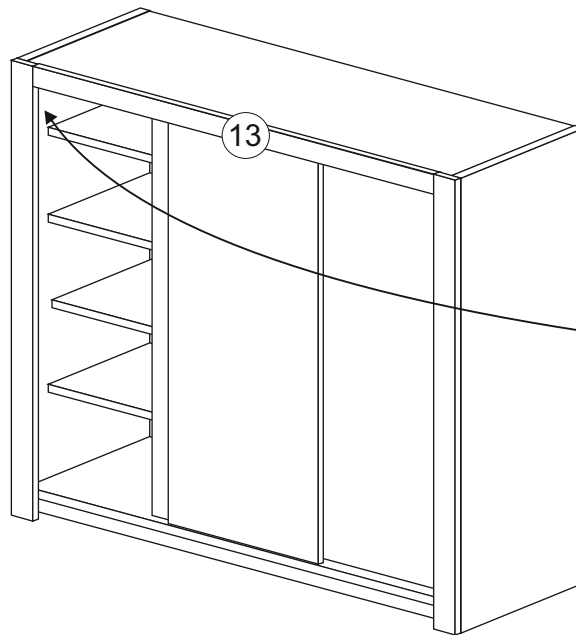
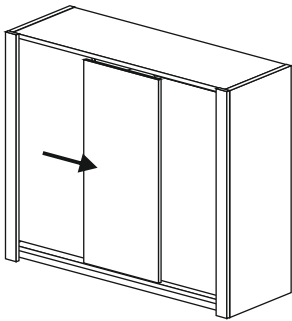
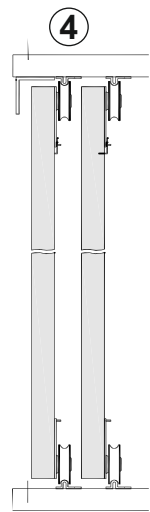
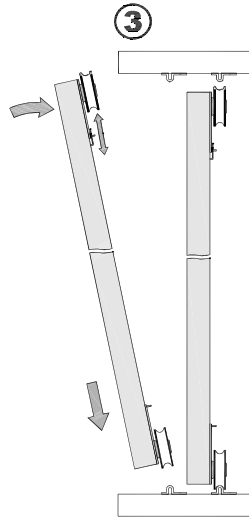
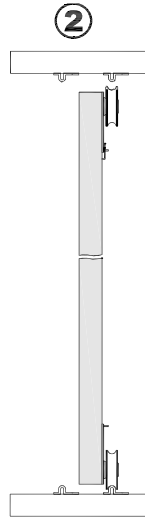
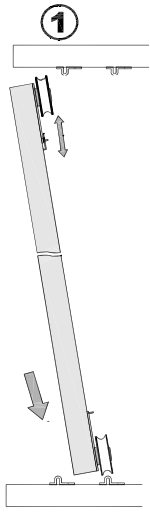

ZASADY UŻYTKOWANIA I KONSERWACJI MEBLI
GRUNDSÄTZE ZUR MÖBELNUTZUNG UND PFLEGE
GUIDLINES FOR FURNITURE USE AND MAINTENANCE

PL

1. Meble należy użytkować w pomieszczeniach suchych przed szkodliwymi wpływami atmosferycznymi .
 2. Montaż mebli należy przeprowadzić zgodnie z instrukcją montażu mebla.
 3. Miejsce montażu mebla w miarę możliwości powinno odbywać się jak najbliżej miejsca docelowego.
 4. Meble przy ustawieniu należy wypoziomować
 5. Przemieszczanie mebli winno być dokonywane poprzez przenoszenie bez dodatkowego obciążenia. Ciągnięcie przesuwanie mebli grozi trwałym nieodwracalnym uszkodzeniem .Podczas przenoszenia należy chwycić za element pionowe. Boki nogi . Nie wolno chwycić za części poziome które mogą być podatne na uszkodzenia tj. blaty szuflady .
 6. Nie należy nadmiernie obciążać mebli ,grozi to ich trwałym uszkodzeniem
 7. W trakcie użytkowania mebli należy okresowo sprawdzać stan połączeń mimosrodowych zaisów i przewodników do zawiasów.
 8. Powierzchnie należy czyścić tylko środkami do pielęgnacji mebli.
-

D

1. Die Möbel sind nur in trockenen Räumen unterzubringen wo sie gegen schädliche Witterungseinflüsse geschützt werden können
 2. Die Montage von Einzelelementen ist gemäß Montageanleitung durchzuführen
 3. Der Montageplatz der Möbel sollen die Möbelstücke horizontal werden.
 5. Die Möbel sind nur ohne zusätzliche Belastung zu bewegen beim Verschieben und am Boden ziehen können dauerhafte Schäden entstehen bei der Bewegung soll immer nur an senkrechten Elementen wie Seitenflächen oder Beinen gehalten werden .waagrechte Bauteile wie Platten Schubladen, dürfen dabei nicht beansprucht werden weil sie Beschädigungsanfällig sein können.
 6. Die Möbel dürfen nicht übermäßig belastet werden denn eine Überbelastung kann dauerhaften Schäden verursachen.
 7. Während der Möbelnutzung soll notfalls der Zustand der außermittigen Verbindungen kontrolliert werden Möbeloberflächen sind nur mit speziellen dazu geeigneten Möbelpflegemitteln zu reinigen.
-

GB

1. Furniture should be used in rooms which are dry and protected against the harmful influences of weather conditions.
2. Furniture should be assembled in accordance with the assembly manual.
3. Furniture should be assembled as close as possible to its intended final location.
4. While positioning the furniture make sure it is levelled
5. Furniture may be moved only by lifting and carrying it over when emptied of its contents. Pushing it over or pulling it along may ruin the furniture permanently. While carrying the furniture over it must be held by its vertical elements , i.e side panels or legs. Furniture cannot be held by its horizontal elements prone to destruction, i.e desktops drawer, etc..
6. Furniture should not be overloaded as this may ruin it permanently.
7. While using the furniture ,the state of the connections between its elements should be checked if necessary.
8. Furniture surface must be cleaned only with furniture maintenance formulas.